

Product Specification Sheet

Customer: MI

Model Name: PNC357DB1-4

Date: 2021/09/09

Version: V01

Customer's Approval		CSOT	
Signature	Date	Approved By	Date
		Reviewed By	Date
		Prepared By:	Date

Record of Revision

Version	Revise Date	Page	Content
V01	2021/09/01	All	Preliminary Specification

Contents

1. GENERAL DESCRIPTION	5
1.1 OVERVIEW	5
1.2 SPECIFICATION SUMMARY	5
2. MECHANICAL SPECIFICATIONS	6
2.1 INTERFACE CONNECTION	6
3. ABSOLUTE MAXIMUM RATINGS	6
3.1 ABSOLUTE RATINGS OF ENVIRONMENT	6
3.2 ELECTRICAL ABSOLUTE RATINGS	7
3.2.1 TFT LCD MODULE	7
4. ELECTRICAL SPECIFICATIONS	7
4.1 FUNCTION BLOCK DIAGRAM	7
4.2 INTERFACE CONNECTIONS	8
4.3 ELECTRICAL CHARACTERISTICS	10
4.4 LCD ELECTRONICS SPECIFICATION	10
4.4.1 BACKLIGHT UNIT	11
4.5 DISPLAY TIMING SPECIFICATIONS	10
4.5.1 Speed Setting	12
4.5.2 Porch Setting	12
4.6 POWER ON/OFF SEQUENCE	12
4.6.1 Power On Sequence	12
4.6.2 Power Off Sequence	14
5. OPTICAL CHARACTERISTICS	16
6. RELIABILITY TEST ITEMS	16
7. DISPLAY QUALITY	21
8. PACKAGING CONDITION	22
8.1 PACKAGE SPECIFICATIONS	错误!未定义书签。
8.2 PACKING METHOD	错误!未定义书签。
8.3 LABEL	错误!未定义书签。
9. ROHS DIRECTIVE	22

版权属于武汉华星光电技术有限公司所有，禁止任何未经授权的使用

The copyright belongs to Wuhan China Star Optoelectronics Technology Co., Ltd.

Any unauthorized use is prohibited.

10. HANDLING PRECAUTIONS22

APPENDIX. OUTLINE DRAWING23

1. GENERAL DESCRIPTION

1.1 OVERVIEW

PNC357DB1-4 is a 12.35" TFT Liquid Crystal Display Low Blue Light module with LED Backlight unit and 60 pins

MIPI interface. This module supports 1600 x 2560 mode and can display 16.7M colors.

1.2 SPECIFICATION SUMMARY

No.	Item	Specification	Unit	Note
1	LCD size	12.35	inch	
2	Resolution	1600 x RGB x 2560		
3	Pixel Arrangement	RGB		
4	Model Type	In-cell TLCM		TDDI
5	TFT Technology	LTPS		
6	Display mode	FFS, Normally Black	--	
7	Active Area	265.96(H) × 166.22(V)	mm	
8	pixel pitch	103.89(H)×103.89(V)	um	
9	Display Colors	16.7M		
10	Contrast Ratio	1400:1(Typ)/1000:1(min)		
11	Color Gamut	DCI-P3 98% (typ) / 95% (min)		
12	Low Blue Light Ratio	50% (max)	%	TUV Method-2 spec
13	LCM Outline Dimension	274.41×174.32 (W/O FPC bent)×3.26	mm	Typical
	TPM Outline Dimension	282.02×187.52 (W/O FPC bent)×3.99	mm	Typical
14	Luminance	500	nits	
15	Surface treatment(UP)	Glare	--	Pol.
16	Refresh rate	60	HZ	
17	interface	MIPI 1port 4lane D-PHY+VESA 1/3 DSC		
18	Wacom AES Pen	support		
19	Method of Inversion	Column Inversion		
20	Power consumption of Panel	0.5(Typ.) 0.6(Max)	W	@Mosaic
	Power consumption of Backlight	3.47(Typ.) 3.6(Max)	W	@500nits.
21	Power consumption of LCD total	3.97(Typ.) 4.2(Max)	W	@Mosaic&@500nits
22	Weight	256(Max)	g	TPM

版权属于武汉华星光电技术有限公司所有，禁止任何未经授权的使用

The copyright belongs to Wuhan China Star Optoelectronics Technology Co., Ltd.

Any unauthorized use is prohibited.

Note :The specified power consumption (with converter efficiency) is under the conditions at VDDI = 1.8 V, AVDD = 5.5V, AVEE = -5.5V, fv = 60 Hz, LED_VCCS = Typ, Duty=100% and Ta = 25 ± 2 °C, whereas mosaic pattern is displayed

2. MECHANICAL SPECIFICATIONS

Parameter		Min.	Typ.	Max.	Unit	Note
Unit outline dimensions	Width	281.94	282.02	282.10	mm	
	Height	187.44	187.52	187.60	mm	W/O FPC bent
	Depth	2.23	2.48	2.68	mm	Thickness (body)
		-	-	4.185	mm	Thickness(w/PCBA)
Weight			246	256	g	

2.1 INTERFACE CONNECTION

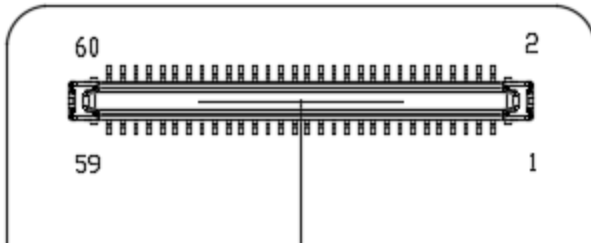

Connector Part No.: WP27MDK-PM60VA1-R15000 (Please refer Appendix Outline Drawing for detail design.)

3. ABSOLUTE MAXIMUM RATINGS

3.1 ABSOLUTE RATINGS OF ENVIRONMENT

Item	Symbol	Value		Unit	Note
		Min.	Max.		
Storage Temperature	T _{ST}	-20	+60	°C	(1)
Operating Ambient Temperature	T _{OP}	0	+50	°C	(1), (2)

版权属于武汉华星光电技术有限公司所有，禁止任何未经授权的使用

The copyright belongs to Wuhan China Star Optoelectronics Technology Co., Ltd.

Any unauthorized use is prohibited.

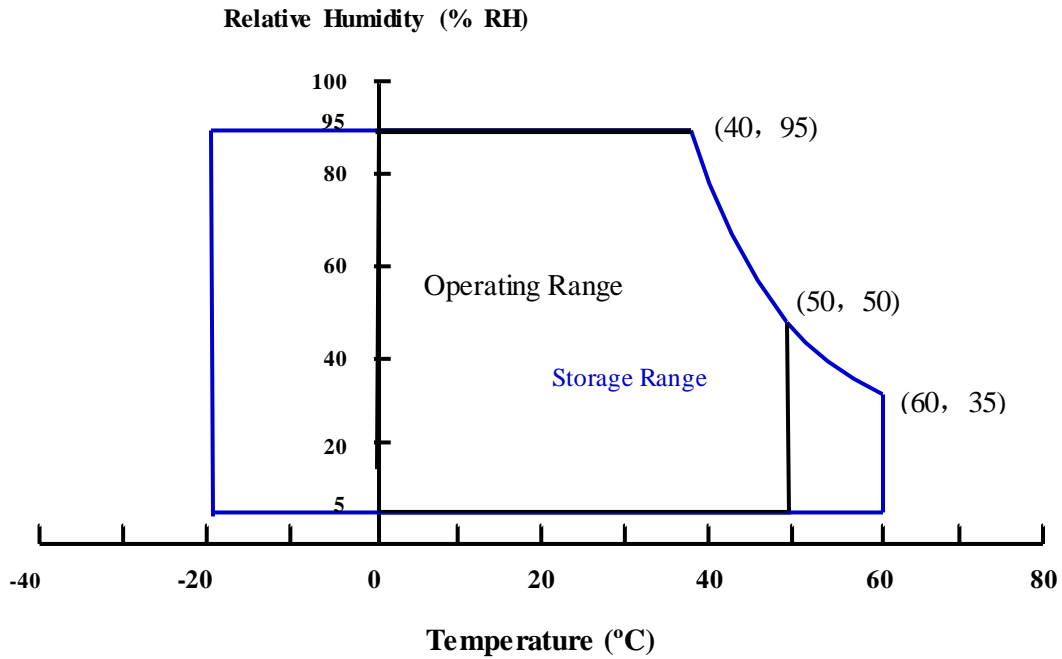

Note (1)

- (a) 95% RH Max. ($T_a \leq 40\text{ }^\circ\text{C}$).
- (b) Wet-bulb temperature should be $39\text{ }^\circ\text{C}$ Max. ($T_a > 40\text{ }^\circ\text{C}$).
- (c) No condensation.

Note (2) The temperature of panel surface should be $0\text{ }^\circ\text{C}$ min. and $60\text{ }^\circ\text{C}$ max.

3.2 ELECTRICAL ABSOLUTE RATINGS

TFT LCD MODULE

Item	Symbol	Value		Unit	Note
		Min.	Max.		
DDIC Power supply	VDDI	0	+1.95	V	(1)
Analog supply voltage	AVDD	0	6	V	(1)
Analog supply voltage	AVEE	-6	0	V	(1)
Converter Input Voltage	LED_VCCS	-0.3	26	V	(1)

Note (1) Stresses beyond those listed in above “ELECTRICAL ABSOLUTE RATINGS” may cause permanent damage to the device. Normal operation should be restricted to the conditions described in “ELECTRICAL CHARACTERISTICS”.

4. ELECTRICAL SPECIFICATIONS

4.1 FUNCTION BLOCK DIAGRAM

版权属于武汉华星光电技术有限公司所有，禁止任何未经授权的使用

The copyright belongs to Wuhan China Star Optoelectronics Technology Co., Ltd.

Any unauthorized use is prohibited.

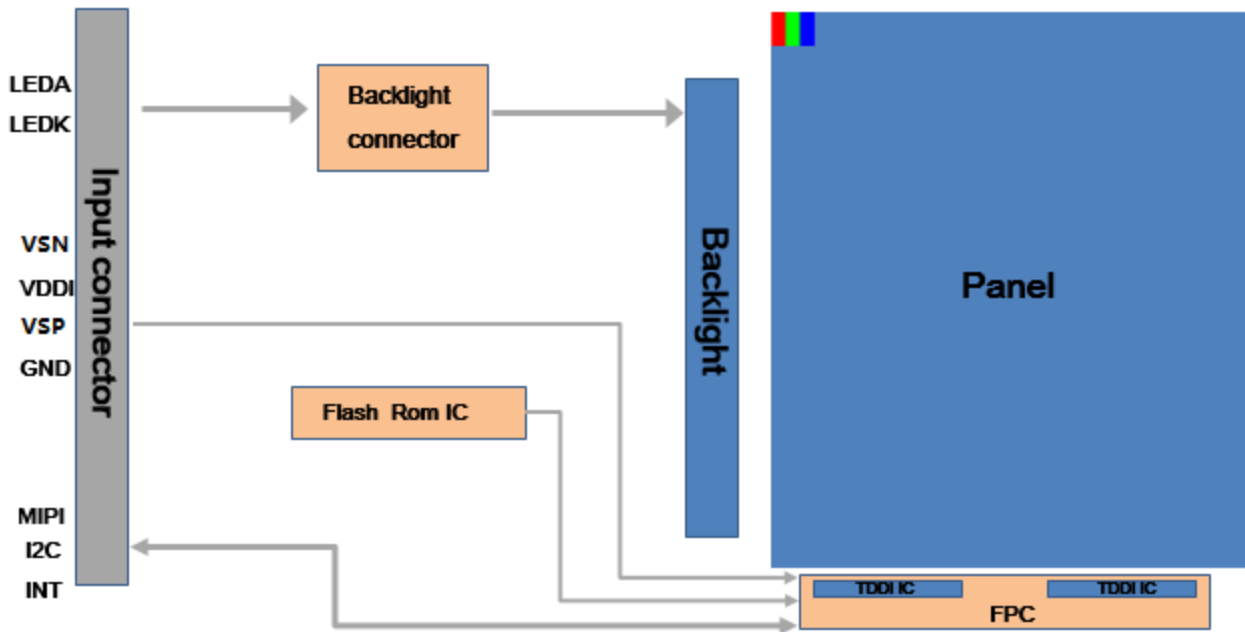

4.2 INTERFACE CONNECTIONS

PIN ASSIGNMENT(Connector Part No.: WP27MDK-PM60VA1-R15000)

59	TSP_SPI_SCL	SPI clk -for touch	60	TE1_M	Suggest output for ESD or debugging.
57	TSP_SPI_MOSI	SPI SDI-for touch	58	GND	Ground
55	TSP_INT	INT-for touch	56	TSP_RST	the RST pin for touch
53	GND	Ground	54	TSP_SPI_SS	SPI CS -for touch
51	MIPI_D3_N	D3N for Dphy	52	TSP_SPI_MISO	SPI SDO-for touch
49	MIPI_D3_P	D3P for Dphy	50	LED_BL_PWM	PWM output for BL control
47	GND	Ground	48	GND	Ground
45	MIPI_D2_N	D2N for Dphy	46	HOST_I2C_SCL	I2C clk -for touch
43	MIPI_D2_P	D2P for Dphy	44	HOST_I2C_SDA	I2C SDA -for touch
41	GND	Ground	42	GND	Ground
39	MIPI_CLK_N	CLKN for Dphy	40		
37	MIPI_CLK_P	CLKP for Dphy	38		
35	GND	Ground	36		
33	MIPI_D1_N	D1N for Dphy	34		
31	MIPI_D1_P	D1P for Dphy	32		

版权属于武汉华星光电技术有限公司所有，禁止任何未经授权的使用

The copyright belongs to Wuhan China Star Optoelectronics Technology Co., LTd.

Any unauthorized use is prohibited.

29	GND	Ground	30		
27	MIPI_D0_N	D0N for Dphy	28	LCD_RST_N	the RST pin for IC
25	MIPI_D0_P	D0P for Dphy	26	NC	NC
23	GND	Ground	24	NC	NC
21	NC	NC	22	VSN	Analog Negative supply voltage for Ic
19	VSP	Analog positive supply voltage for Ic	20	VSN	Analog Negative supply voltage for Ic
17	VSP	Analog positive supply voltage for Ic	18	NC	NC
15	NC	NC	16	K2	Power for LED2 Cathode
13	VDDI	digital supply voltage for Ic	14	K4	Power for LED4 Cathode
11	VDDI	digital supply voltage for Ic	12	K6	Power for LED6 Cathode
9	NC	NC	10	K8	Power for LED8 Cathode
7	LED_A	Power for LED Anode	8	K1	Power for LED1 Cathode
5	LED_A	Power for LED Anode	6	K3	Power for LED3 Cathode
3	LED_B	Power for LED Anode	4	K5	Power for LED5 Cathode
1	LED_B	Power for LED Anode	2	K7	Power for LED7 Cathode

Note :The pixel is shown in the following figure.

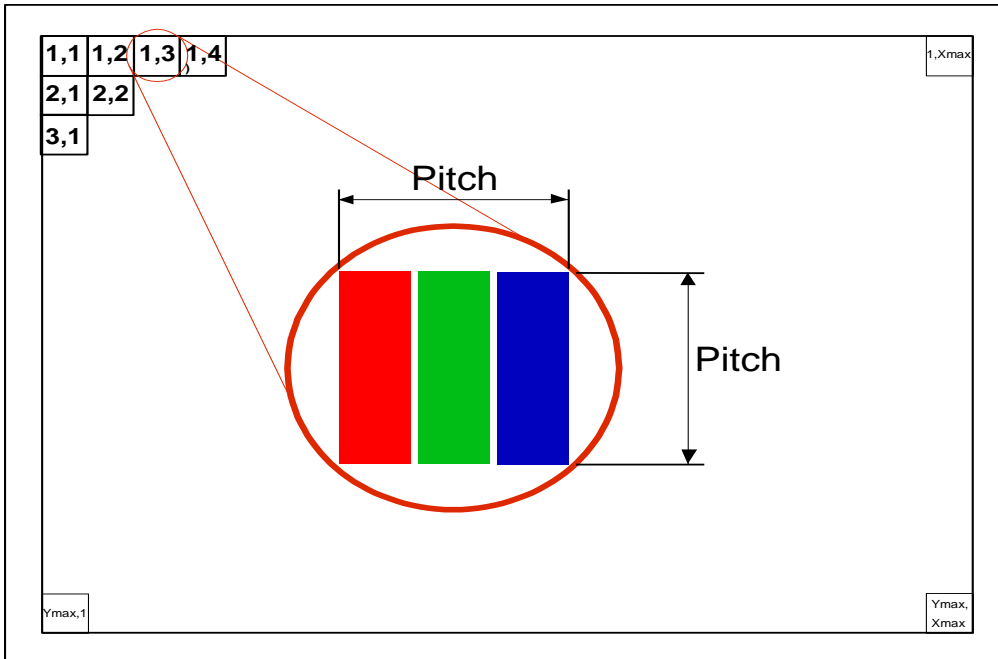

版权属于武汉华星光电技术有限公司所有，禁止任何未经授权的使用

The copyright belongs to Wuhan China Star Optoelectronics Technology Co., Ltd.

Any unauthorized use is prohibited.

4.3 ELECTRICAL CHARACTERISTICS

4.4 LCD ELETRONICS SPECIFICATION

Parameter	Symbol	Value			Unit	Note	
		Min.	Typ.	Max.			
DDIC Power supply	VDDI	1.85	1.9	1.95	V	(1)	
Analog supply voltage	AVDD	5.5	5.6	5.7	V	(1)	
Analog supply voltage	AVEE	-5.7	- 5.6	-5.5	V	(1)	
Ripple Voltage	V_{RP}	-	-	100	mV	(1)	
Power consumption of Panel	Mosaic	P_{LCD}	-	0.5	0.6	W	(3)

Note (1) The ambient temperature is $T_a = 25 \pm 2 \text{ }^\circ\text{C}$.

Note (2) The specified power supply current is under the conditions at $V_{DDI} = 1.8 \text{ V}$, $AVDD = 5.5\text{V}$, $AVEE = -5.5\text{V}$, $T_a = 25 \pm 2 \text{ }^\circ\text{C}$, $T_a = 25 \pm 2 \text{ }^\circ\text{C}$, DC Current and $f_v = 60 \text{ Hz}$, whereas a power dissipation check pattern below is displayed.

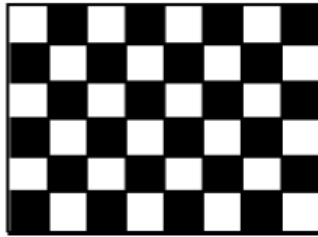

LED CONVERTER SPECIFICATION

Parameter		Symbol	Value			Unit	Note
			Min.	Typ.	Max.		
PWM Level	PWM High Level		0.8 x VDDI	-	VDDI	V	
	PWM Low Level		0	-	0.2VDDI	V	
LED Power consumption		P _L	-	3.465	3.654	W	(2)
LEDA Input power supply voltage		LED_A	23.4	24.75	26.1	V	
LEDK Input power supply Current		LED_Kn	-	17.5		mA	(3)

Measurement Conditions: Shown as the following figure. LED_A& LED_Kn =Typ, Ta = 25 ± 2 °C, Duty=100%.

Note(2) P_L = I_L × V_L (With/o LED converter transfer efficiency);

Note(3) The specified LED power supply current is under the conditions at “LED_A& LED_Kn = Typ .”, Ta = 25 ± 2 °C, Duty=100%.

BACKLIGHT UNIT

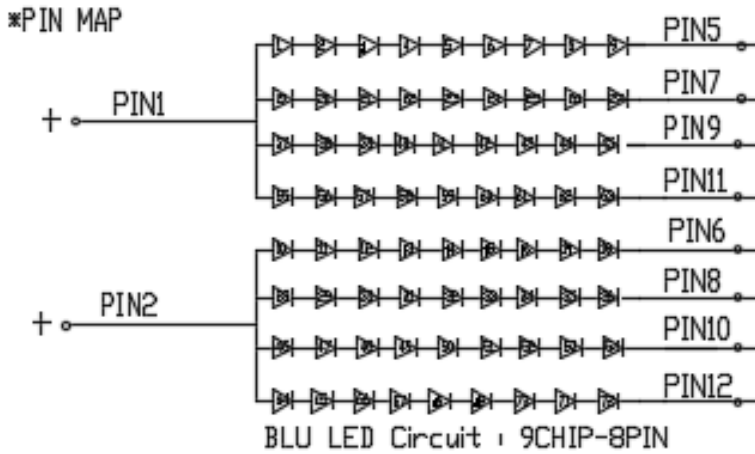

Ta = 25 ± 2 °C

Parameter	Symbol	Value			Unit	Note
		Min.	Typ.	Max.		
LED Light Bar Power Supply Voltage	V _L	-	-	26.1	V	(1)(2)
LED Light Bar Power Supply Current	LED_K(1-8)	-	140	-	mA	(Duty100%)
Power Consumption	P _L	-	-	3.654	W	
LED Life Time	L _{BL}	15000	-	-	Hrs	

Note (1)LED current is measured by utilizing a high frequency current meter :

Note (2) For better LED light bar driving quality, it is recommended to utilize the adaptive boost converter with current balancing function to drive LED light-bar.

版权属于武汉华星光电技术有限公司所有。禁止任何未经授权的使用

The copyright belongs to Wuhan China Star Optoelectronics Technology Co., Ltd.

Any unauthorized use is prohibited.

4.5 DISPLAY TIMING SPECIFICATIONS

4.5.1 Speed Setting

Item	Unit	Value
Frame Rate	Hz	60
Pixel Clock	MHz	84.5
MIPI Lane	Lane	1port* 4Lane
MIPI Speed	sps	676M

4.5.2 Porch Setting

Item	Symbol	Value
Horizontal Sync Width	HSW	20
Horizontal Back Porch	HBP	40
Horizontal Active	HACT	1600
Horizontal Front Porch	HFP	118
Vertical Sync Width	VSW	4
Vertical Back Porch	VBP	18
Vertical Active	VACT	2560
Vertical Front Porch	VFP	60

Note: The porch setting should be adjust according to the set systemcondition and Modify VSW/VBP/VFP is prohibited.

4.6 POWER ON/OFF SEQUENCE

4.6.1 Power On Sequence

版权属于武汉华星光电技术有限公司所有，禁止任何未经授权的使用

The copyright belongs to Wuhan China Star Optoelectronics Technology Co., Ltd.

Any unauthorized use is prohibited.

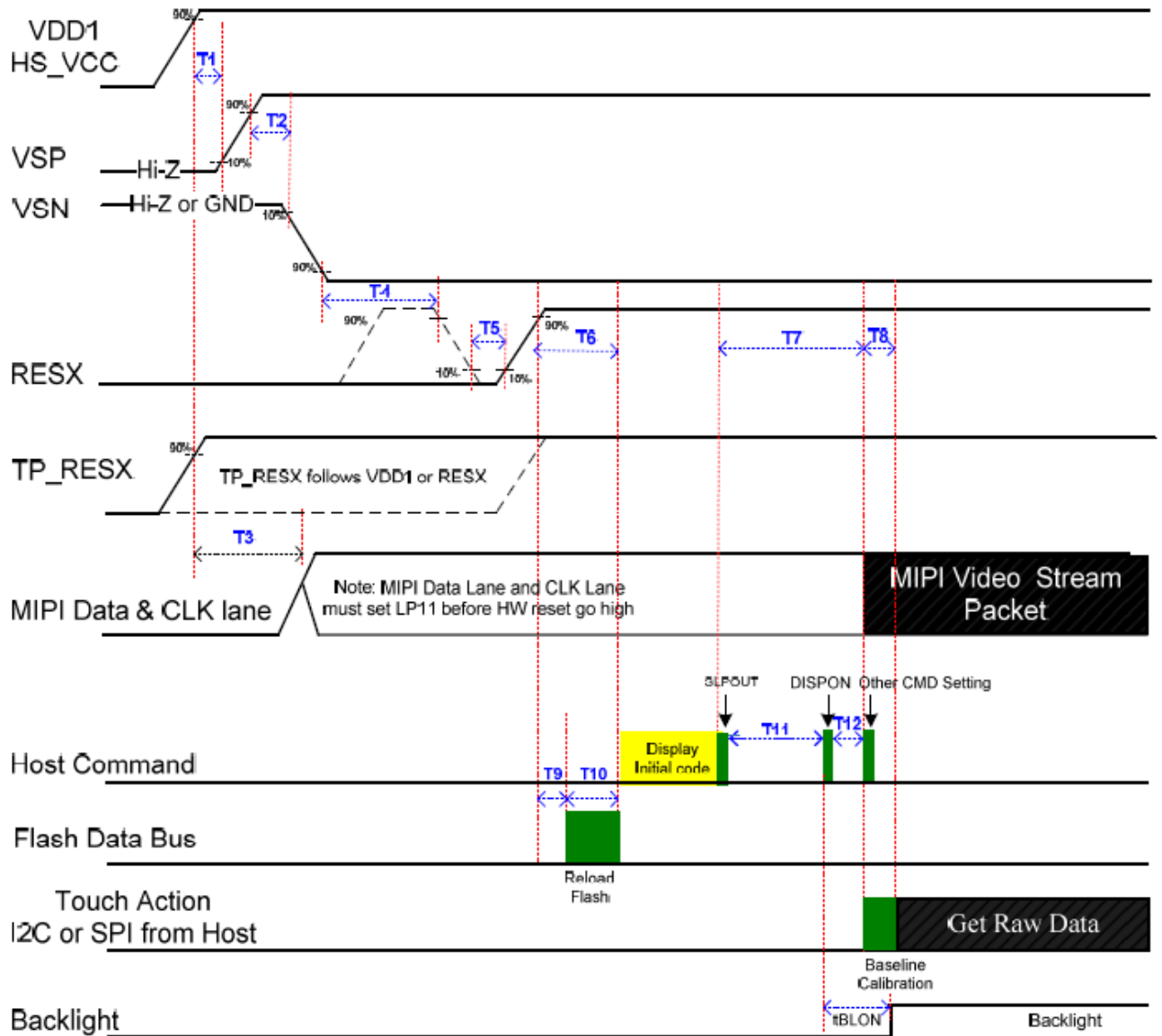

Symbol	Description	Min	Max	Unit	Note
T1	VDD1 to VSP	1	-	ms	
T2	VSP to VSN	1	-	ms	
T3	VDD1 to MIPI Lane	1	-	ms	
T4	Power Ready to Global Reset	1	-	ms	
T5	Global Reset Keep Low	1	-	ms	TP Reset is the same
T6	Global Reset to Display initial code by HOST	55	-	ms	
T7	Video Stream Start and Host TP Data Bus Active	140	-	ms	OTP reload time: 15ms BLK packet: 1 frame Init frame: 2 frame
T8	AP Start to Get Raw Data	48	-	ms	
T9	Reset to Flash Reload	5	-	ms	
T10	Flash Reload Time	55	-	ms	SPI 10 MHZ
T11	Sleep Out to Display On	120	-	ms	
T12	Display On to IC Ready	20	-	ms	
tBLON	Display On Command to BL On time	40	-	ms	

4.6.2 Power Off Sequence

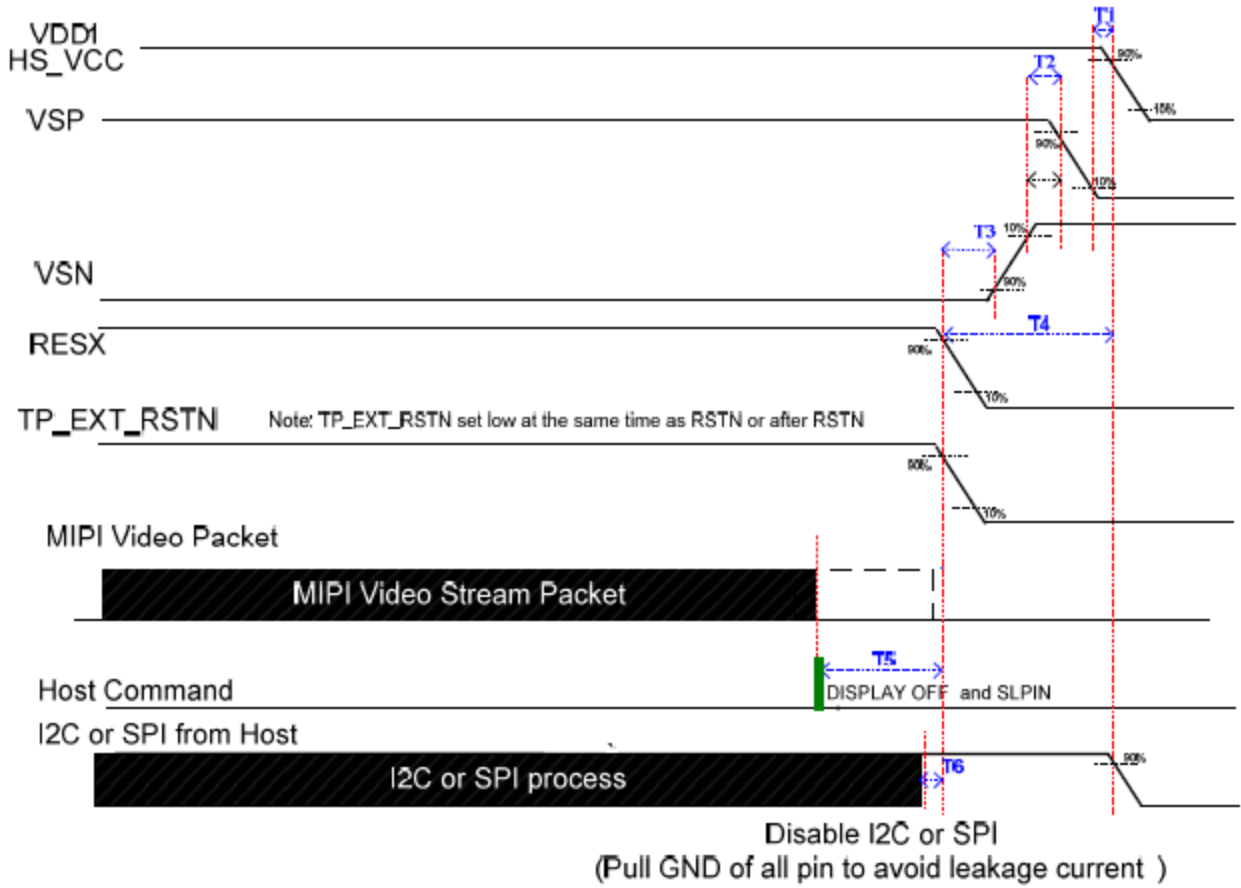

	Description	Min.	Typ.	Max.	Unit	Note
T1	VDD1 to VSP Power Off	0			ms	
T2	VSP to VSN Power Off	0			ms	
T3	Reset to VSN Start to Power Off	0			ms	
T4	Reset to VDD1 Start to Power Off	1			ms	
T5	Sleep In to Reset	7			Frame	
T6	Touch Interface to Reset	1			Frame	

5. Optical characteristics

Ta=25°C

Parameter	Symbol	Condition	Min.	Typ.	Max.	Unit	Note			
Viewing angle range	Left/Right	CR > 10	-	89	-	Deg.	(1), (3), (4), (6)			
	Upper/Lower		-	89	-					
Contrast ratio	CR	$\theta = 0 \text{ deg.}$	1000	1400		-	(2), (4), (6)			
Response time	T_r+T_d		-	-	21	ms	(5)			
	GTG		-	-	25	ms				
Chromaticity of white	x		Typ.	-0.025	0.313	Typ.	+0.025	-		
	y				0.329			-		
Chromaticity of red	x				0.680			-		
	y				0.320			-		
Chromaticity of green	x				0.265			-		
	y				0.690			-		
Chromaticity of blue	x				0.150			-		
	y	0.060			-					
Gamut(1931)	%	95%			98%			-	DCI-P3	Normal operation (2), (6)
Luminance of White	Y_{\square}	425			500			-	cd/m ²	
Delta E	Tracking of CIExyY for Gray 40~255 levels	-	1.5	2.5	-	(9)				
White uniformity 5pt	δ_w	$\theta = 0 \text{ deg.}$	80	-	-	%	(8)			
White uniformity 13pt	δ_w	$\theta = 0 \text{ deg.}$	70	-	-	%	(2), (8)			
Gamma		W	2.0	2.2	2.4		(10)			
Crosstalk	/	/	/	/	2%		(11)			
Flicker	60Hz	Flicker 画面	/	/	-30	dB	(12)			
Low blue light ratio	(415~455)/ (400~500)	/	-	-	50	%	TUV Method-2 spec			

※The measurement shall be taken 5 minutes after lighting the LCM at the following rating.

※The optical characteristics shall be measured in a dark room or equivalent.

Note (1) Measurement of viewing angle range

Note (2) Measurement of luminance and Chromaticity and Contrast.

版权属于武汉华星光电技术有限公司所有，禁止任何未经授权的使用

The copyright belongs to Wuhan China Star Optoelectronics Technology Co., Ltd.

Any unauthorized use is prohibited.

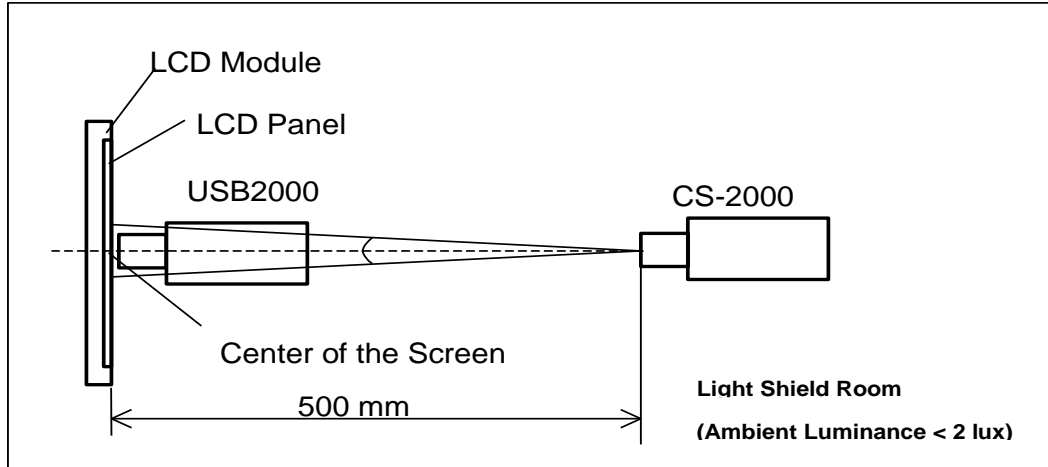

Measurement of Contrast, Luminance, Chromaticity, White variation, Crosstalk and Color temperature variation

Note (3) Definitions of viewing angle range:

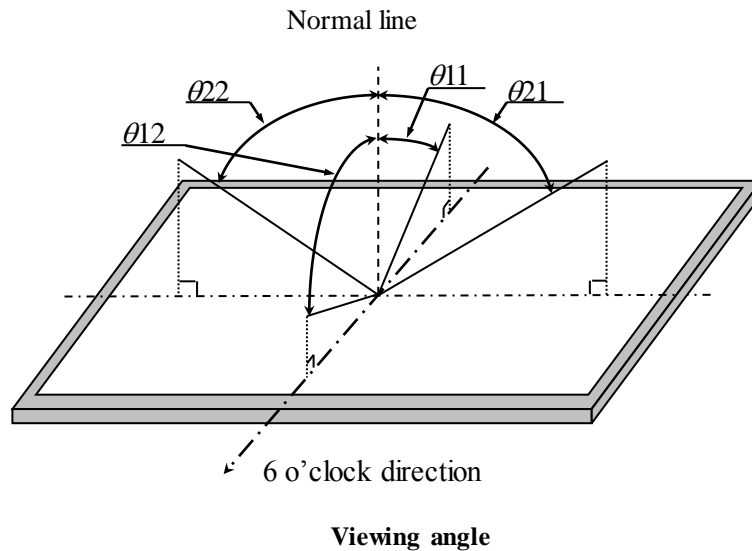

Note (4) Definition of contrast ratio:

The contrast ratio is defined as the following.

$$\text{Contrast Ratio} = \frac{\text{Luminance(Brightness) with all pixels white}}{\text{Luminance(Brightness) with all pixels Black}}$$

Note (5) Definition of response time:

The response time is defined as the following figure and shall be measured by switching the input signal for "black" and "white" .

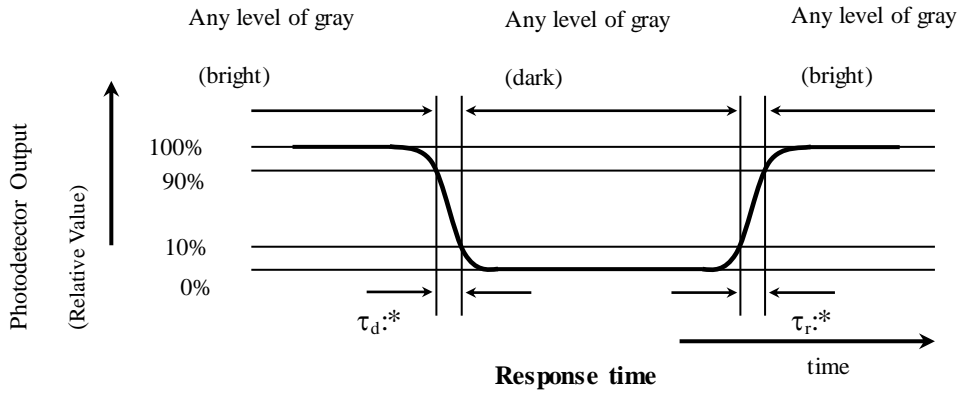

Note (6) This shall be measured at center of the screen.

Note (7) The Luminance of White is the average of 5 points measurements (4,5,7,9,10) showing in the Fig.9-5.

Note (8) Definition of white uniformity:

White uniformity of 5 points is defined as the following with 5 measurements(4,5,7,9,10).

$$\delta_{W1} = \frac{\text{Maximum Luminance of 5 Points(Brightness)}}{\text{Minimum Luminance of 5 Points(Brightness)}}$$

White uniformity of 13 points is defined as the following with 13 measurements(1~13).

$$\delta_{W2} = \frac{\text{Maximum Luminance of 13 Points(Brightness)}}{\text{Minimum Luminance of 13 Points(Brightness)}}$$

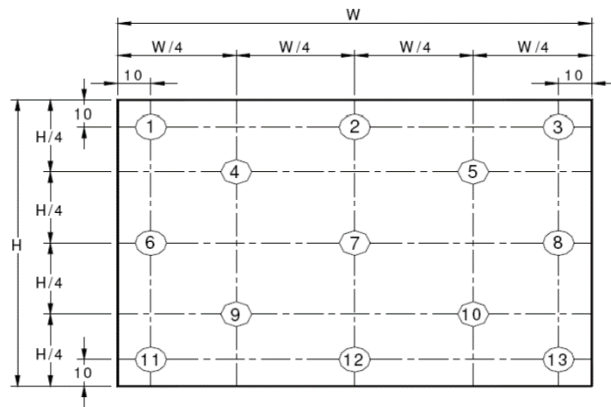

13/5 point pattern

Note (9): Definition of Delta E

- Measure a CIE x, y, Y values for a set of white colors from 40 to 255 levels;
- Calculate X, Y, Z by x, y, Y values ; Calculate L, a, b by X, Y, Z

版权属于武汉华星光电技术有限公司所有。禁止任何未经授权的使用

The copyright belongs to Wuhan China Star Optoelectronics Technology Co., Ltd.

Any unauthorized use is prohibited.

$$L^* = 116 f(Y/Y_n) - 16$$

$$a^* = 500[f(X/X_n) - f(Y/Y_n)]$$

$$b^* = 200[f(Y/Y_n) - f(Z/Z_n)]$$

where

$$f(X/X_n) = (X/X_n)^{1/3} \quad \text{if} \quad (X/X_n) > (24/116)^3$$

$$f(X/X_n) = (841/108)(X/X_n) + 16/116 \quad \text{if} \quad (X/X_n) \leq (24/116)^3$$

and

$$f(Y/Y_n) = (Y/Y_n)^{1/3} \quad \text{if} \quad (Y/Y_n) > (24/116)^3$$

$$f(Y/Y_n) = (841/108)(Y/Y_n) + 16/116 \quad \text{if} \quad (Y/Y_n) \leq (24/116)^3$$

and

$$f(Z/Z_n) = (Z/Z_n)^{1/3} \quad \text{if} \quad (Z/Z_n) > (24/116)^3$$

$$f(Z/Z_n) = (841/108)(Z/Z_n) + 16/116 \quad \text{if} \quad (Z/Z_n) \leq (24/116)^3$$

$$\Delta E = [(a^*)^2 + (b^*)^2]^{1/2}$$

Note (10): Definition of Gamma

For all uniform gray (n,n,n), respective color patterns(n,0,0)/(0,n,0)/(0,0,n) the luminance has to be measured.

The normalized luminance $l_j(n)$ is calculated by

$$l_j(n) = \frac{L_j(n) - L(0)}{L_j(255) - L(0)}$$

with

n: Graylevel, n=0,1,2,3,.....254,255

j: Color Scale (primaries + white)

$L(0,255)$: Luminance of Black/White

$L_j(n)$: Luminance of Graylevel n in color j

$l_j(n)$: Normalized Luminance of Graylevel n in Color j
Gamma: Gray level 0-10 and 245-255 不卡控;

2.20±0.2(Gray level 10~ 20 & Gray level 230~245);

2.20±0.2(Gray level 20~230), 取前三位有效数字判定结果;

Note (11): Definition of Crosstalk

Crosstalk measured with PR730、CS2000

Test Pattern as below:

版权属于武汉华星光电技术有限公司所有。禁止任何未经授权的使用

The copyright belongs to Wuhan China Star Optoelectronics Technology Co., Ltd.

Any unauthorized use is prohibited.

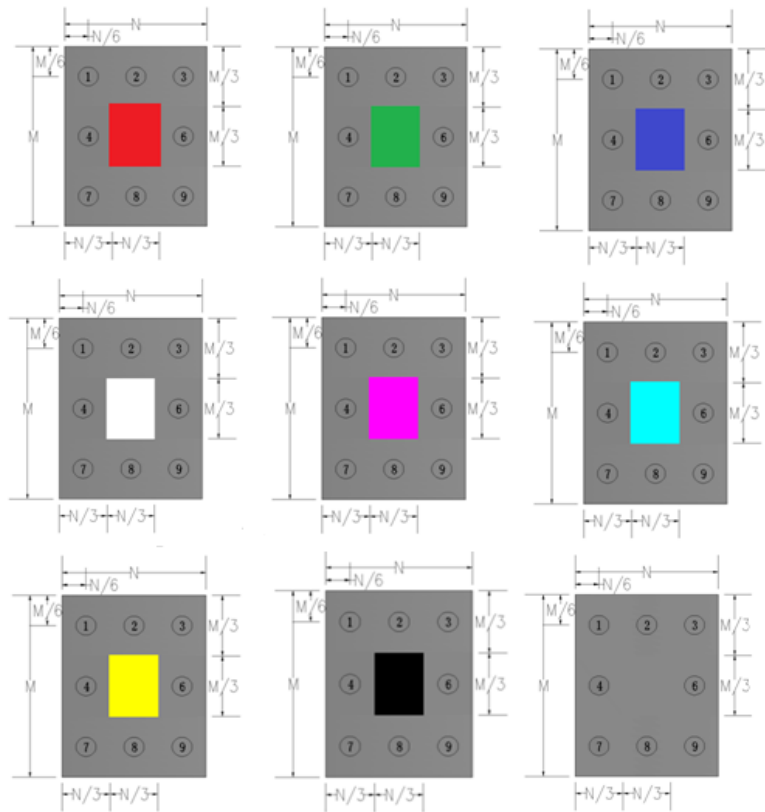

- Red crosstalk(n)%= $|R(n)-Gr(n)|/Gr(n)*100%$ (n=1~9 , except 5)
- Green crosstalk(n)%= $|G(n)-Gr(n)|/Gr(n)*100%$ (n=1~9 , except 5)
- Blue crosstalk(n)%= $|B(n)-Gr(n)|/Gr(n)*100%$ (n=1~9 , except 5)
- White crosstalk(n)%= $|W(n)-Gr(n)|/Gr(n)*100%$ (n=1~9 , except 5)
- Cyan crosstalk(n)%= $|C(n)-Gr(n)|/Gr(n)*100%$ (n=1~9 , except 5)
- Magenta crosstalk(n)%= $|M(n)-Gr(n)|/Gr(n)*100%$ (n=1~9 , except 5)
- Yellow crosstalk(n)%= $|Y(n)-Gr(n)|/Gr(n)*100%$ (n=1~9 , except 5)
- Black crosstalk(n)%= $|K(n)-Gr(n)|/Gr(n)*100%$ (n=1~9 , except 5)

Which n means the dot No. In the Cross-talk Test Pattern;

X(n) means the brightness of the No.n spots in Cross-talk Test Pattern of R/G/B/W/C/M/Y/K.

Gr(n) means the brightness of the No.n spots in Gray Test Pattern;

Note (12): Definition of Flicker

- Flicker measured with ELDIM Optiscope SA(with the distance of 50cm)、CA310、A-TAKT V-5HSC(close to the screen), and it should be measured with flicker pattern at the center point of the LCD screen in dark room after 5 minutes operation.
- Flicker measured with the wany of JEITA at 60Hz.
- Flicker pattern: Column Inversion

版权属于武汉华星光电技术有限公司所有。禁止任何未经授权的使用

The copyright belongs to Wuhan China Star Optoelectronics Technology Co., Ltd.

Any unauthorized use is prohibited.

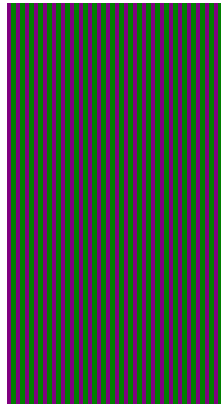

6. Reliability Test Items

No.	Test Item	Conditions
1	High temperature storage test	60°C , 240h
2	Low temperature storage test	-20°C , 240h
3	Low temperature operation test	0°C , 500h
4	High temperature & high humidity operation test	50°C , 80~85%RH , 1000hrs
5	Thermal shocktest	-20°C/30min、 60°C/30min 100cycles
6	TC	-10±2°C/18minutes±5%、 30±2°C/18minutes±5% 100cycles
7	ESD	150pF[330Ω],Contact:±8KV,Air:±15KV
8	Vibration	1.5G , 10->200Hz , For x , y , z axis , 30min for each axis
9	shock	50G 18msec. trapezoidal (2) 210G 3msec. half-sine 1 for each ± x, y, z direction, total 6 times for (1),(2) Power off

[Result Evaluation Criteria] Under the display quality test condition with normal operation state.

Do not change these condition as such changes may affect practical display function.

[Normal operation state] temperature : + 15°C~+ 35°C , Humidity : 45~75% , Atmospheric pressure : 86~106kPa

7. Display Quality

The display quality of the color TFT-LCD Module shall be in compliance with the Incoming Inspection Standard.

8. Packaging Condition (TBD)

9. RoHS Directive

This LCD Module is compliant with RoHS Directive.

10. Handling Precautions

- a) Be sure to turn off the power supply when inserting or disconnecting the cable .Please insert for too much stress not to join a connector in the case of insertion of a connector.
- b) Be sure to design the cabinet so that the Module can be installed without any extra stress such as warp or twist.
- c) Since the front polarizer is easily damaged, pay attention not to scratch it.
- d) Wipe off water drop immediately. Long contact with water may cause discoloration or spots.
- e) When the panel surface is soiled, wipe it with absorbent cotton or other soft cloth.
- f) Since the panel is made of glass, it may break or crack if dropped or bumped on hard surface. Handle with care.
- g) Since CMOS LSI is used in this Module, take care of static electricity and injure the human earth when handling. Observe all other precautionary requirements in handling components.
- h) This Open-cell has its circuitry PCBs on the side and should be handled carefully in order not to be stressed.
- i) Laminate film is attached to the Module surface to prevent it from being scratched. Peel the laminate film off slowly just before the use with strict attention to electrostatic charges. Ionized air shall be blown over during the action. Blow off the 'dust' on the polarizer by using an ionized nitrogen gun, etc. Working under the following environments is desirable.
 - All workers wear conductive shoes, conductive clothes, conductive fingerstalls and grounding belts without fail.
 - Use Ionized blower for electrostatic removal, and peel of the laminate film with a constant speed. (Peeling of it at over 2 seconds)
- j) The polarizer surface on the panel is treated with Anti Glare . In case of attaching protective board over the LCD, be careful about the optical interface fringe etc. which degrades display quality.
- k) Do not expose the LCD Module to a direct sunlight, for a long period of time to protect the Module from the ultra violet ray.
- l) When handling LCD Modules and assembling them into cabinets, please be noted that long-term storage in the environment of oxidization or deoxidization gas and the use of such materials as reagent, solvent, adhesive, resin, etc. which generate these gasses, may cause corrosion and discoloration of the Modules.

版权属于武汉华星光电技术有限公司所有。禁止任何未经授权的使用

The copyright belongs to Wuhan China Star Optoelectronics Technology Co., LTd.

Any unauthorized use is prohibited.

- m) Liquid crystal contained in the panel may leak if the LCD is broken. Rinse it as soon as possible if it gets inside your eye or mouth by mistake.
- n) Disassembling the Module can cause permanent damage and should be strictly avoided.(Except for protection film of the panel.)
- o) Be careful when using it for long time with fixed pattern display as it may cause afterimage.(Please use a screen saver etc., in order to avoid an afterimage.)
- p) If a minute particle enters in the Module and adheres to an optical material, it may cause display non-uniformity issue, etc. Therefore, fine-pitch filters have to be installed to cooling and inhalation hole if you intend to install a fan.
- q) Epoxy resin (amine series curing agent), silicone adhesive material (dealcoholization series and oxime series), tray forming agent (azo compound) etc, in the cabinet or the packing materials may induce abnormal display with polarizer film deterioration regardless of contact or noncontact to polarizer film.Be sure to confirm the component of them.
- r) Do not use polychloroprene. If you use it, there is some possibility of generating Cl₂ gas that influences the reliability of the connection between LCD panel and driver IC.
- s) Do not put a laminate film on LCD Module, after peeling of the original one. If you put on it, it may cause discoloration or spots because of the occurrence of air gaps between the polarizer and the film.
- t) Ground module bezel to stabilize against EMI and external noise.

Appendix. OUTLINE DRAWING

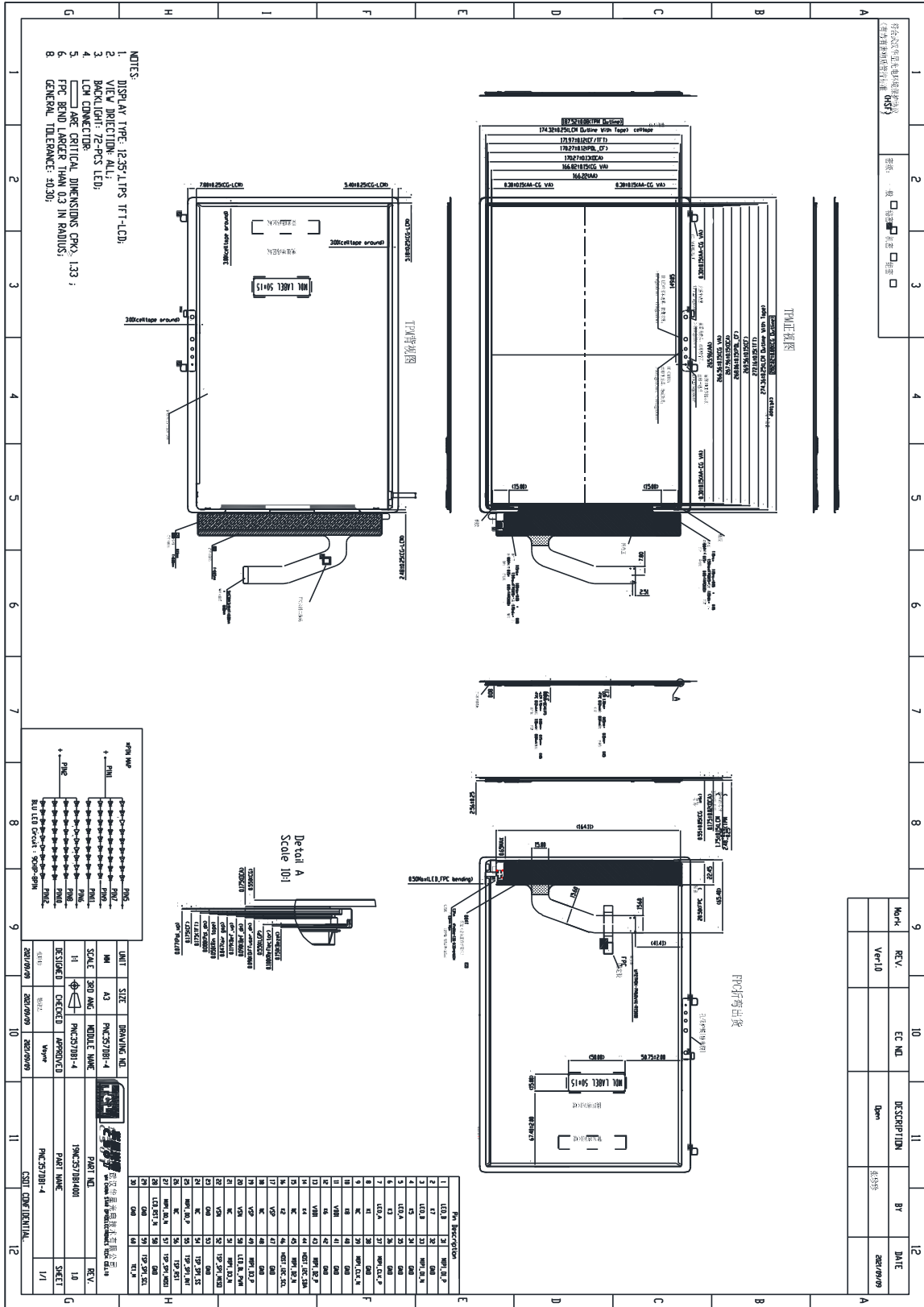

版权属于武汉华星光电技术有限公司所有，禁止任何未经授权的使用
The copyright belongs to Wuhan China Star Optoelectronics Technology Co., Ltd.
Any unauthorized use is prohibited.